

PCI-4Pack-2

Custom for VEDA

Intelligent IP CARRIER for *PCI*[™] systems
Up to Four IndustryPack[®] Modules
Dual Ported SRAM between PCI and DSP C31

REFERENCE MANUAL

736-21-000-4000

Version 2.1

August 1998

ALPHI TECHNOLOGY CORPORATION

6202 S. Maple Avenue #120

Tempe, AZ 85283 USA

Tel: (602) 838-2428

Fax: (602) 838-4477

PCI-4Pack REFERENCE MANUAL

NOTICE

The information in this document has been carefully checked and is believed to be entirely reliable. While all reasonable efforts to ensure accuracy have been taken in the preparation of this manual, ALPHI TECHNOLOGY assumes no responsibility resulting from omissions or errors in this manual, or from the use of information contain herein.

ALPHI TECHNOLOGY reserves the right to make any changes, without notice, to this or any of ALPHI TECHNOLOGY's products to improve reliability, performance, function or design.

ALPHI TECHNOLOGY does not assume any liability arising out of the application or use of any product or circuit described herein; nor does ALPHI TECHNOLOGY convey any license under its patent rights or the rights of others.

ALPHI TECHNOLOGY CORPORATION

All Rights Reserved

This document shall not be duplicated, nor its contents used for any purpose, unless express permission has been granted in advance.

PCI-4Pack REFERENCE MANUAL

TABLE OF CONTENTS

1. GENERAL DESCRIPTION	1
1.1 INTRODUCTION	1
1.2 FUNCTIONAL DESCRIPTION	1
1.3 REFERENCE MATERIALS LIST	3
2. HOST (PCI) SIDE	4
2.1 PCI CONFIGURATION REGISTERS	4
2.2 PCI BASE ADDRESS REGISTERS	4
2.3 PCI OPERATION REGISTERS	4
3. C31 SIDE	5
3.1 INTERNAL ORGANIZATION	5
3.2 PCI INTERFACE	5
3.3 DUAL PORT MEMORY	6
3.4 IP INTERFACE and PAGED MEMORY	7
3.5 LOCAL MEMORY AND REGISTER MAP SUMMARY	7
3.6 RESET SIGNALS	10
3.7 LOCAL DSP INTERRUPT SOURCES	10
4. JUMPER DESCRIPTIONS	11
5. LED INDICATORS	12
6. CONNECTIONS	12
6.1 IP I/O CONNECTORS	12
6.2 SERIAL RS232 PORT (CON11)	13
6.3 SERIAL RS422 / RS485 PORT (CON2)	13
6.4 DSP SERIAL PORT (CON3)	13
6.5 EMULATOR CONNECTION (P16)	14
6.6 POWER FOR STAND ALONE OPERATION (P12)	14
6.7 FACTORY USE (P15)	14
7. STANDALONE OPERATION	14
7.1 PCI RESET	14
7.2 PCI BUS CLOCK	14

1. GENERAL DESCRIPTION

1.1 INTRODUCTION

The **PCI-4Pack** is a PCI expansion card in a standard full length form factor. The **PCI-4Pack** provides mechanical support and the electrical interfaces for four single width IP modules, or two double width IP modules. Multiple **PCI-4Pack** boards may be installed in a single system. The primary features of the **PCI-4Pack** are as follows:

- Support for up to four IP modules
- 8 MHz or 32 MHz IP operation via jumper selection
- On board DSP C31 to offload I/O operation from host or standalone applications
- Direct memory mapped access to the C31 from PCI bus via AMCC 5933 PCI Chip
- Direct dual ported memory access from PCI bus and C31 (up to 4 Mbytes)
- Full interrupt support of host and DSP C31
- Supports double-wide form factor IndustryPack®
- Front panel I/O connectors (for 2 IPs. Other 2 IPs require additional panel)

1.2 FUNCTIONAL DESCRIPTION

A functional block diagram of the **PCI-4Pack** is presented below in Figure 1-1. The component placement is depicted in Figure 1-2. The **PCI-4Pack** can operate as a slave that is managed by the host processor on the PCI bus or it can operate in a standalone mode of operation without a host. The IP modules share a common clock that can be jumpered for 8 or 32 MHz operation. Each pair of single width IPs, or each double width IP is individually selectable as to clock rate.

The **PCI-4Pack** is supported by ALPHI Technology under *Windows NT* by a **Board Support Package** which is supplied with the card. Other documentation supplied with the card will describe this support in full detail.

The card is also supported by a **DSP Support Library** providing the following features:

- Common access routines for communications with the host
- Mapping C language standard input and output by the DSP to the onboard 8530 serial chip
- Identify the applicable card resources and parameters

All these are provided in a manner consistent across ALPHI Technology platforms. Other documentation supplied with the card will describe the support in full detail.

A bootloader provided on the card allows for control by the HOST and for independent operation in stand alone operation. User code can be downloaded to FLASH memory and booted automatically on reset. Access to the card can be made both by the HOST PCI bus and serially through the 8530.

PCI-4Pack REFERENCE MANUAL

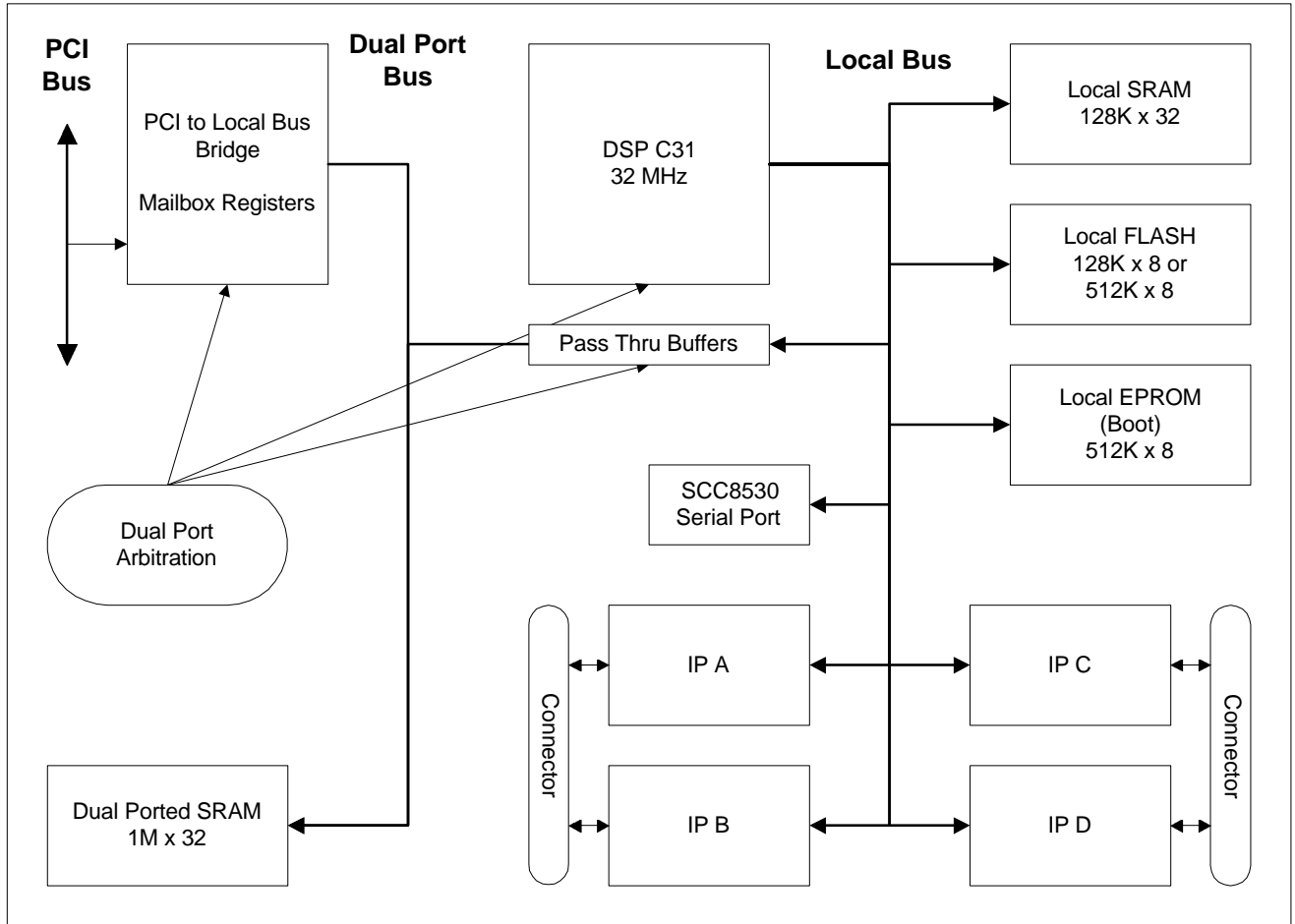

Figure 1.1: Block Diagram

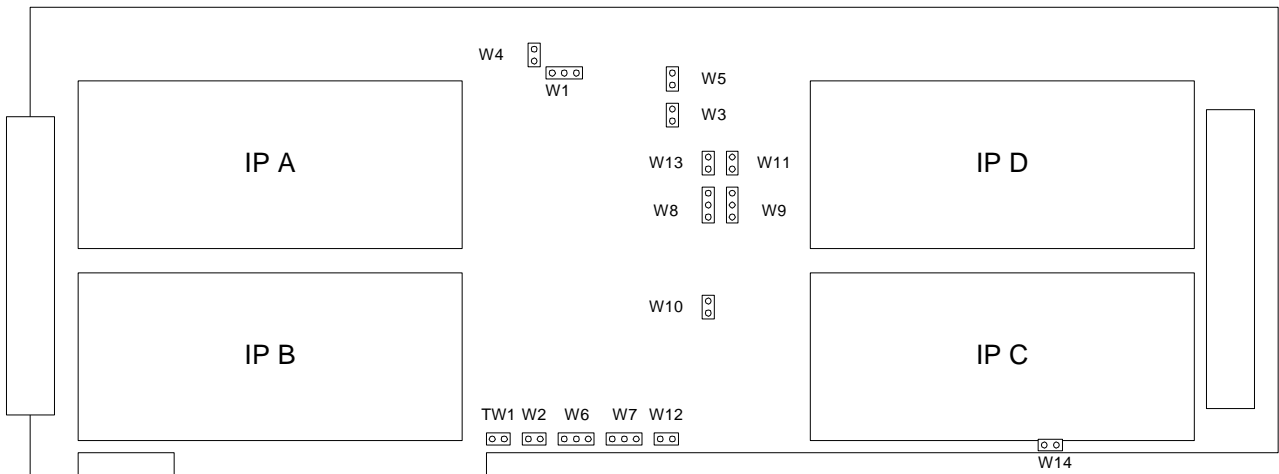

Figure 1.2: Jumper Locations

PCI-4Pack REFERENCE MANUAL

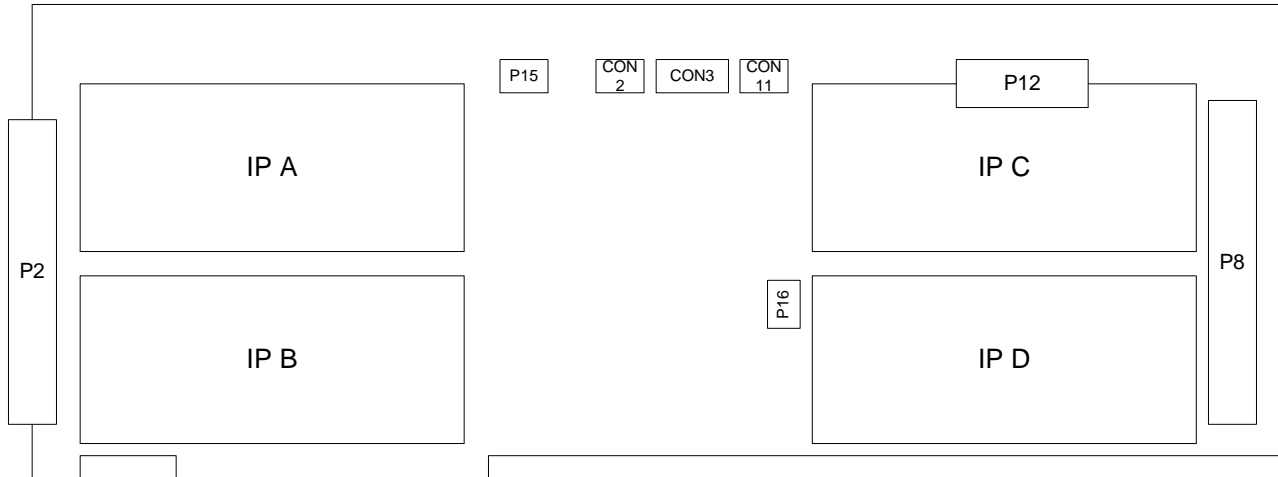

Figure 1.3: Connector Locations

1.3 REFERENCE MATERIALS LIST

The reader should refer to the PCI Local Bus Specification for a detailed explanation of the PCI bus architecture and timing requirements. This specification is available from the following source:

PCI Special Interest Group
PO Box 14070
Portland, OR 97214
Tel: (800) 433-5177
Tel: (503) 797-4207
Fax: (503) 234-6762

The reader is also referred to the S5933 PCI Controller data book:

AMCC Applied Micro Circuits Corporation
6195 Lusk Boulevard
San Diego, CA 92121-2793
Tel: (800) 755-2622
<http://www.amcc.com>

WindowsNT and Windows95 Programming Tools:

BlueWater Systems
144 Railroad Ave. Suite #217
Edmonds, WA 98020
Tel: (206) 771-3610
Fax: (206) 771-2742
E-Mail: info@bluewatersystems.com
Web: <http://www.bluewatersystems.com>

2. HOST (PCI) SIDE

2.1 PCI CONFIGURATION REGISTERS

The card presents the following configuration values to the PCI system, based on the values stored in the NVRAM device read by the AMCC PCI interface chip.

Register	Value (Meaning)
Vendor ID	0x13c5 (ALPHI Technology)
Device ID	0x0401 (PCI-4Pack)
Revision ID	0x00
Class Code	0xff0000 (Device does not fit into defined class codes)
Interrupt Line	0xff
Interrupt Pin	A
Multifunction Device	No
Build In Self Test	No
Latency Timer	0x00
Minimum Grant	0x00
Maximum Latency	0x00
Expansion ROM Size	None

Table 2.1: PCI Configuration Registers

2.2 PCI BASE ADDRESS REGISTERS

The card requests base address regions from the PCI system after RESET, based on the values stored in the NVRAM device read by the AMCC PCI interface chip.

The decode addresses of these regions are assigned by the host processor. The **PCI-4Pack** uses 3 of the 5 AMCC mapped base address registers. The AMCC is normally programmed at the factory to request the following resources from the PCI BIOS:

BAR	From	To	Description	Type
0	0x00000000	0x00000003F	AMCC PCI Operation Registers	MEM
1	0x00000000	0x00FFFFFF	Reserved for future use	MEM
3	0x00000000	0x003FFFFFF	Dual Port Memory	MEM
3	0x00400000	0x01FFFFFF	Reserved for future use	MEM

Table 2.2: Base Addresses and Use

NOTE: The AMCC has been programmed to request memory above 1 Mbytes.

2.3 PCI OPERATION REGISTERS

The host processor communicates with the **PCI-4Pack** module via the AMCC pass-through interface. After the base address registers have been programmed by the PCI configurator, incoming PCI I/O or Memory cycles are translated into either accesses to the AMCC chip or

PCI-4Pack REFERENCE MANUAL

to the Dual Port SRAM. The PCI Operation Registers of the AMCC 5933 chip are depicted below:

Offset	Register Name
0x00	OMB1 Outgoing Mailbox Register 1
0x04	OMB2 Outgoing Mailbox Register 2
0x08	OMB3 Outgoing Mailbox Register 3
0x0C	OMB4 Outgoing Mailbox Register 4
0x10	IMB1 Incoming Mailbox Register 1
0x14	IMB2 Incoming Mailbox Register 2
0x18	IMB3 Incoming Mailbox Register 3
0x1C	IMB4 Incoming Mailbox Register 4
0x20	FIFO Register Port (bi-directional)
0x24	MWAR Master Write Address Register
0x28	MWTC Master Write Transfer Counter
0x2C	MRAR Master Read Address Register
0x30	MRTC Master Read Transfer Counter
0x34	MBEF Mailbox Empty/Full Status
0x38	INTCSR Interrupt Control/Status Register
0x3C	MCSR Bus Master Control/Status Register

Table 2.3: AMCC Registers (HOST)

For more information about these registers refer to the AMCC PCI controller manual.

3. C31 SIDE

3.1 INTERNAL ORGANIZATION

The **PCI-4Pack** card is divided into different sections. Each section and its relationship to other sections will be discussed. The **PCI-4Pack** sections are:

- PCI interface
- Dual Port Memory
- IP interface

3.2 PCI INTERFACE

The local DSP processor communicates with the PCI bus through the AMCCS9533 chip that provides bi-directional FIFO and Mailbox registers. The **PCI-4Pack** can function as both a servant (PCI target) or as a master (PCI initiator) for DMA access. The following interface descriptions refer to the PCI interface as seen by the local DSP. The AMCC registers are located at DSP address 0xf00080.

3.2.1 BI-DIRECTIONAL FIFO

Two separate FIFO data paths are implemented within the AMCCS9533, a read FIFO that allows data transfers from the module to the PCI bus and a write FIFO that transfers data

PCI-4Pack REFERENCE MANUAL

from the PCI to the module. Size of the FIFO is 32 bit X 8. Read and write DMA access to the host can occur via the FIFO registers if it is supported by the software on the HOST and is enabled. Alternatively, the FIFO registers can utilize a polled scheme on the HOST and DSP. Both FIFOs are accessed via access to the same location as seen by the DSP, offset 0x08.

3.2.2 MAILBOX REGISTERS

The Mailbox registers of the AMCCS9533 provide a bi-directional data path that can be used to send data or software control information between the HOST and the **PCI-4Pack** module. Interrupts can be enabled based on a specific mailbox event. There are 4 incoming mailboxes and 4 outgoing mailboxes. Each mailbox is 32 bits wide. The address offsets for the mailboxes are shown below in Table 3-1.

3.2.3 ADDITIONAL REGISTERS

The AMCCS5933 PCI controller has a set of additional registers to control and monitor the behavior of the CPCI interface. Only the Add-on FIFO port is used by the **PCI-4Pack**.

The address offsets of these registers are shown below in Table 3-1.

Offset	Register Name
0x00	Incoming Mailbox Reg 1
0x01	Incoming Mailbox Reg 2
0x02	Incoming Mailbox Reg 3
0x03	Incoming Mailbox Reg 4
0x04	Outgoing Mailbox Reg 1
0x05	Outgoing Mailbox Reg 2
0x06	Outgoing Mailbox Reg 3
0x07	Outgoing Mailbox Reg 4
0x08	Add-on FIFO port
0x09	Bus master write Address Register
0x0A	Add-on Pass through Address
0x0B	Add-on Pass through Data
0x0C	Bus master read Address Register
0x0D	Add-on Mailbox Empty/full Status
0x0E	Add-on Interrupt Control
0x0F	Add-on General Control/Status Register

Table 3.1: AMCC Registers (DSP)

For more information about these registers refer to the AMCC PCI controller manual.

3.3 DUAL PORT MEMORY

The dual port ram is directly accessed via memory writes and reads to locations in the range 00B00000h - 00BFFFFFh if 1 MWORD of memory is installed. This memory operates

PCI-4Pack REFERENCE MANUAL

at 3 or more wait states of the C31, with more when the HOST is accessing it as well. The HOST has priority during arbitration for a given cycle.

3.4 IP INTERFACE and PAGED MEMORY

The ID and IO space for the IPs are directly accessed based on the memory map below. IP memory space is overlaid with the EPROM and FLASH space, and is controlled via CTRL 1.

3.5 LOCAL MEMORY AND REGISTER MAP SUMMARY

NAME	START	END	DATA	R/W	COMMENTS
SRAM	\$000000	\$01FFFF	D00-D31	R/W	Zero wait state static RAM
EPROM	\$400000	\$47FFFF	D00-D07	R/W	512K x 8
FLASH	\$480000	\$49FFFF	D00-D07	R/W	Software write protected
IPMEMSL_A	\$400000	\$7FFFFFFF	D00-D15	R/W	IP_A memory (8 Mbytes)
IPMEMSL_B	\$400000	\$7FFFFFFF	D00-D15	R/W	IP_B memory (8 Mbytes)
IPMEMSL_C	\$400000	\$7FFFFFFF	D00-D15	R/W	IP_C memory (8 Mbytes)
IPMEMSL_D	\$400000	\$7FFFFFFF	D00-D15	R/W	IP_D memory (8 Mbytes)
DP_SRAM	\$B00000	\$BFFFFFFF	D00-D31	R/W	Dual Port SRAM (4Mbytes)
CTRL1	\$F00000	\$F00000	D01-D03	W	Controls internal settings
CTRL2	\$F00002	\$F00002	D01-D03	W	Controls internal settings
C31_STAT1	\$F00008	\$F00008	D00-D07	R	IP interrupt status
C31_STAT2	\$F00009	\$F00009	D00-D07	R	IP DMA status
C31_STAT3	\$F0000A	\$F0000A	D00-D07	R	Miscellaneous status
BERR_RST	\$F00028	\$F00028	D00-D07	W	Reset Bus Error Status
IPSTROBE	\$F00038	\$F00038	D00-D31	W	Assert *IPSTROBE
SCC8530	\$F00040	\$F00043	D00-D07	R/W	Serial communication port
AMCC	\$F00080	\$F000FF	D00-D31	R/W	AMCC REGISTERS
IDSEL_A	\$F00400	\$F0043F	D00-D15	R/W	IP_A ID Space
INTGNT_A	\$F00440	\$F0047F	D00-D07	R	Interrupt vector from IP_A
IOSEL_A	\$F00480	\$F004BF	D00-D15	R/W	IP_A I/O Space
IDSEL_B	\$F00500	\$F0053F	D00-D15	R/W	IP_B ID Space
INTGNT_B	\$F00540	\$F0057F	D00-D07	R	Interrupt vector from IP_B
IOSEL_B	\$F00580	\$F005BF	D00-D15	R/W	IP_B I/O Space
IDSEL_C	\$F00600	\$F0063F	D00-D15	R/W	IP_C ID Space
INTGNT_C	\$F00640	\$F0067F	D00-D07	R	Interrupt vector from IP_C
IOSEL_C	\$F00680	\$F006BF	D00-D15	R/W	IP_C I/O Space
IDSEL_D	\$F00700	\$F0073F	D00-D15	R/W	IP_D ID Space
INTGNT_D	\$F00740	\$F0077F	D00-D07	R	Interrupt vector from IP_D
IOSEL_D	\$F00780	\$F007BF	D00-D15	R/W	IP_D I/O Space

Table 3.2: DSP Memory Map

3.5.1 CTRL1 (Write Only)

BIT 07	BIT 06	BIT 05	BIT 04	BIT 03	BIT 02	BIT 01	BIT 00
				BANKSEL1	BANKSELO	32BIT_AB	FLASH

FLASH, BANKSELO, BANKSEL1 **Memory Page Selection**

The FLASH and EPROM, and the four IP memory spaces are all paged into a common DSP address range starting at 0x400000. Selection of the appropriate page is accomplished by programming the FLASH, BANKSELO, and BANKSEL1 bits.

CTRL1	Page Selection
0x0	FLASH and EPROM (default)
0x1	IP_A Memory Space
0x5	IP_B Memory Space
0x9	IP_C Memory Space
0xD	IP_D Memory Space

Table 3-3: Memory Page Selection

32BIT_AB **32-bit Width Enable**

Setting this bit to a one enables the IP interface A and B for 32-bit transfers. Setting this bit to a zero disables the 32-bit transfers (default setting). This bit must be set to a one when using a double width IP. Note that the DSP always reads or writes in 32-bits, however only the lower 16 bits are valid when 32BIT_AB = 0.

3.5.2 CTRL2 (Write Only)

BIT 07	BIT 06	BIT 05	BIT 04	BIT 03	BIT 02	BIT 01	BIT 00
				EXTRIG_EN	CBERR_EN	32BIT_CD	TCLK1_EN

TCLK1_EN, EXTRIG_EN **Signal routing to IPSTROBE**

See the following table for routing signals to *IPSTROBE.

TCLK1_EN,	EXTRIG_EN	Result
0	0	Connect DSP Timer 1 output to *IPSTROBE
1	0	Software writes to register IPSTROBE (0xF00038) output to *IPSTROBE
X	1	External TTL trigger on W13 output to *IPSTROBE

32BIT_CD **32-bit Width Enable**

Setting this bit to a one enables the IP interface C and D for 32-bit transfers. Setting this bit to a zero disables the 32-bit transfers (default setting). This bit must be set to a one when using a double width IP. Note that the DSP always reads or writes in 32-bits, however only the lower 16 bits are valid when 32BIT_CD = 0.

CBERR_EN **Local Bus Error enable**

Any access to a non-existent IP will never complete since no device will assert *IPACK.

PCI-4Pack REFERENCE MANUAL

To prevent this from happening, and hanging the DSP, any access to an IP also starts a timer to ensure that the cycle completes. The fact that this event occurs is reported in C31_STAT3, and can be cleared by writing to BERR_RST.

If this bit is set, an IP interrupt is generated. Otherwise, no interrupt is generated.

3.5.3 C31_STAT1 INTERRUPT STATUS REGISTER

BIT 07	BIT 06	BIT 05	BIT 04	BIT 03	BIT 02	BIT 01	BIT 00
IP_D IREQ1	IP_D IREQ0	IP_C IREQ1	IP_C IREQ0	IP_B IREQ1	IP_B IREQ0	IP_A IREQ1	IP_A IREQ0

Each IP module can generate two different interrupts. When any Industry Pack generates an interrupt, the corresponding interrupt is ORed with other pending interrupts. The DSP can read this register to determine which interrupts are pending.

3.5.4 C31_STAT2 DMA STATUS REGISTER

BIT 07	BIT 06	BIT 05	BIT 04	BIT 03	BIT 02	BIT 01	BIT 00
IP_D DMA1	IP_D DMA0	IP_C DMA1	IP_C DMA0	IP_B DMA1	IP_B DMA0	IP_A DMA1	IP_A DMA0

The Industry Pack Specification allows for the possibility for an IP to request a DMA transfer. The **PCI-4Pack** does not directly support this option. However it is possible for the DSP to recognize a DMA request by polling the C31_STAT2 register. There is no interrupt support or direct DMA support by the DSP.

3.5.5 C31_STAT3 MISCELLANEOUS STATUS REGISTER

BIT 07	BIT 06	BIT 05	BIT 04	BIT 03	BIT 02	BIT 01	BIT 00
					Jumper W3	Jumper W5	CBERR

CBERR *Bus Error Status*

The DSP C31 can read this status register to know that a access to an IP has not responded by asserting *IPACK. This status is reset with a write to BERR_RST.

JUMPER W3, W5 *Status of Hardware Jumpers*

These hardware jumpers are available for the use of the customer. If the jumper is installed, the bit reads as a 0.

3.5.6 BERR_RST

A write to this location will reset the CBERR bit in the C31_STAT3 register.

3.5.7 IPSTROBE

If the CTRL2 Register is configured to allow it, a write to this location will trigger a pulse on the *IPSTROBE line to all the IPs.

3.5.8 SERIAL PORT

The DSP processor on the **PCI-4Pack** has access to a SCC85C30 serial communication controller. The 8530 provides an RS232C asynchronous serial communication port and an RS422 port.

The bootloader and hardware support libraries supplied with the **PCI-4Pack** utilizes the RS232C port for a console for standard input and output by the DSP. The customer may alternatively wish to write his own software to use this port. Examples are provided in the **Board Support Package**.

There is hardware support for many RS422 and RS485 applications including HDLC, SDLC, and multidrop configurations. Clocking can be provided externally or internally.

3.6 RESET SIGNALS

The **PCI-4Pack** can be reset from two different sources:

- At power on, the watchdog timer will hold the C31 RESET line and the IP reset lines low for 200 ms.
- The AMCC has a bit called SYSRST which the HOST can toggle to reset the DSP and IP resets. Software should hold the RESET asserted for 200 mS to meet the IP specifications

3.7 LOCAL DSP INTERRUPT SOURCES

The local DSP has four interrupt lines. The source of each interrupt is listed in the table below. Additionally, at reset, the INT1 line is pulsed to tell the C31 to find the EPROM image at 0x400000 (if boot mode is MC).

SOURCE	ENABLE SIGNAL	INTERRUPT LEVEL
SCC8530	Inside SCC8530	INT0
Bus Error	CBERR_EN	INT0
AMCC	Inside 5933	INT1
AMCC FIFO: WR not Full RD not Empty	None	INT2
IP interrupt	None	INT3

Table 3-4

4. JUMPER DESCRIPTIONS

JUMPER	FACTORY SETTING	DESCRIPTION
W1	1-2	EPROM Addressing: 1-2 for 1 and 4 MB; 2-3 for 1 MB only.
W2	None	If installed, forces PCI reset high for stand alone operation. Hosted operation is default.
W3	None	Available to user for software configuration. The state is available in C31_STAT3.
W4	None	Factory use only.
W5	None	Available to user for software configuration. The state is available in C31_STAT3.
W6	2-3	IP A, B Clock Speed. 1-2 for 32 MHz, 2-3 for 8 MHz. 8 MHz is default.
W7	2-3	IP C, D Clock Speed. 1-2 for 32 MHz, 2-3 for 8 MHz. 8 MHz is default.
W8	2-3	Select input from RS422 pair 7 and 8. 1-2 to connect to receive clock of 8530; 2-3 to connect to CTS of 8530. CTS is default.
W9	2-3	Select output to RS422 pair 4 and 5. 1-2 to output TXCLK generated by 8530. 2-3 to output RTS from the 8530. RTS is default.
W10	None	DSP Boot Mode: MC/~MP. The card's boot mechanism is designed to operate in MC mode, booting from the EPROM.
W11	None	RS422 Driver Mode. If present, drive both outputs on RTS; otherwise drive always. Drive always is default.
W12	None	When shorted, provides DSP and IP reset.
W13	None	External trigger to generate *IPSTROBE pulse, if enabled in CTRL2 register.
W14	1-2	Shorted when DSP operates at 32 MHz and OSC3 not installed; not when OSC3 installed for custom DSP frequency.
TW1	None	If installed, connects 32 MHz clock to PCI clock for stand alone operation and access to AMCC. Hosted operation is default.

Table 4.1 Jumper Descriptions

5. LED INDICATORS

There are six LED indicators visible at the PCI card bracket. They are not marked with a legend on the bracket, but they are labeled on the PCB as L1 – L6 where L1 is at the top of the card.

The LEDs have the following meanings:

LED	Meaning
L1	DSP is accessing IP D.
L2	DSP is accessing IP C.
L3	DSP is reading a register in the AMCC.
L4	DSP is writing a register in the AMCC.
L5	DSP is accessing IP B.
L6	DSP is accessing IP A.

Table 5.1 LED Descriptions

6. CONNECTIONS

6.1 IP I/O CONNECTORS

50 pin flat cable connectors are used to route all the IP I/O signals off the card. The mating connector reference is **HIROSE H1F6-50D-1.27R**. ALPHI Technology can supply transition modules and cable assemblies to meet any special requirements. Contact the factory for additional information.

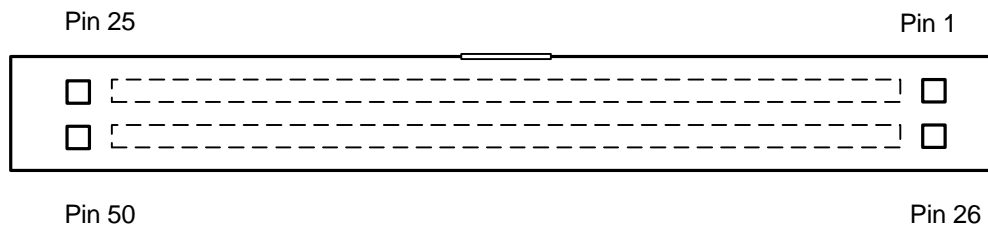

Figure 6.1: IP I/O CONNECTORS

6.1.1 IP A (P2) and B (P3)

The I/O signals for IPs A and B are directly routed off the card through the front panel.

6.1.2 IP C (P8) and D (P9)

The I/O signals for IPs C and D are placed such that they can only be accessed from inside the HOST chassis. ALPHI Technology has an optional panel and ribbon cable assembly which can be placed adjacent to the card to route these signals out of the HOST chassis.

6.2 SERIAL RS232 PORT (CON11)

Port A of the 8530 is configured as RS232 port, and it serves as the console output for the bootloader and any DSP programs linked with the ALPHI_IO.LIB library discussed in the **DSP Support Library**. The pinout is described in the table below. An optional serial cable is available from the factory which connects to CON11 and terminates in a 9 PIN D, suitable for connection to a computer or terminal.

Pin	Description	Pin	Description
1	No Connection	2	No Connection
3	Receive Data	4	No Connection
5	Transmit Data	6	No Connection
7	Clear To Send	8	No Connection
9	Request To Send	10	No Connection

Table 6.1: Serial RS232 Port (CON11)

6.3 SERIAL RS422 / RS485 PORT (CON2)

Port B of the 8530 is configured as a combination RS422 / RS485 port. The port can be configured to communicate with many other devices in a dedicated direct link as well as a multidrop link, depending on jumper settings. The pinout is described in the table below.

Pin	Direction	Description	Pin	Direction	Description
1	Output	Transmit Data +	2	Output	Transmit Data -
3	Input	Receive Data +	4	Output	RTS + or TXCLK +
5	Output	RTS - or TXCLK -	6	Input	Receive Data -
7	Input	CTS + or RXCLK +	8	Input	CTS - or RXCLK -

Table 6.2: Serial RS422 / RS485 Port (CON2)

6.4 DSP SERIAL PORT (CON3)

The serial shift register of the DSP is also available for use as desired by the customer. The input and outputs are connected to 55194 and 55195 bipolar line drivers and receivers as shown in the following table. See the DSP Processor manual for details on how to use the serial port.

Pin	Description	Pin	Description
1	FSR0 -	2	FSX0 +
3	FSR0 +	4	FSX0 -
5	Ground	6	Ground
7	DR0 -	8	DX0 +
9	DR0 +	10	DX0 -
11	Ground	12	Ground
13	CLKR0 -	14	CLKX0 +
15	CLKR0 +	16	CLKX0 -

Table 6.3: DSP Serial Port (CON3)

6.5 EMULATOR CONNECTION (P16)

This connector is used to connect the emulator to the C31 DSP. It follows the standard form as described by TI in their processor manual.

6.6 POWER FOR STAND ALONE OPERATION (P12)

When the board is operating in stand alone mode, this connector can be used in place of the PCI connector to supply power to the card and IPs. The card requires +5 volts; the +12 and -12 volts are only necessary if the installed IPs require it.

Pin	Use
1	+5 Volts
2	Ground
3	+12 Volts
4	Ground
5	-12 Volts

Table 6.4: Power for Stand Alone Operation (P12)

6.7 FACTORY USE (P15)

This connector is used at the factory for programming the FPGA.

7. STANDALONE OPERATION

When the board is operated without a PCI HOST, two signals must be driven in order to assure correct operation. These signals are provided by placing the correct jumpers on the board when in stand alone operation. If the board is returned to a PCI hosted environment, these jumpers must be removed, or they will interfere with the correct operation of the PCI host.

When the board is operated in stand alone mode, the board can be operated under an emulator and by downloading and executing programs via the serial port under control of the bootloader.

7.1 PCI RESET

This signal must be pulled high by inserting a jumper in location xx for stand alone operation. In a hosted environment, it must be removed.

7.2 PCI BUS CLOCK

The AMCC requires that a PCI BUS clock be present for its internal operation. This signal must be driven by the internal clock oscillator when operated in stand alone operation. This is accomplished by inserting a jumper in location xx for stand alone operation. In a hosted environment, it must be removed.