

# **PMC-1553**

## **MIL-STD-1553**

### **PMC Module**

#### **REFERENCE MANUAL**

718-12-000-4000

Revision 1.2

JUNE 1998

**ALPHI TECHNOLOGY CORPORATION**

**6202 S. Maple Avenue #120**

**Tempe, AZ 85283 USA**

**Tel : (602) 838-2428**

**Fax: (602) 838-4477**

## **NOTICE**

The information in this document has been carefully checked and is believed to be entirely reliable. While all reasonable efforts to ensure accuracy have been taken in the preparation of this manual, ALPHI TECHNOLOGY assumes no responsibility resulting from omissions or errors in this manual, or from the use of information contain herein.

ALPHI TECHNOLOGY reserves the right to make any changes, without notice, to this or any of ALPHI TECHNOLOGY's products to improve reliability, performance, function or design.

ALPHI TECHNOLOGY does not assume any liability arising out of the application or use of any product or circuit described herein; nor does ALPHI TECHNOLOGY convey any license under its patent rights or the rights of others.

**ALPHI TECHNOLOGY CORPORATION**  
**All Rights Reserved**

This document shall not be duplicated, nor its contents used for any purpose, unless express permission has been granted in advance.

TABLE OF CONTENTS

<b>GENERAL DESCRIPTION</b>	<b>1</b>
<b>INTRODUCTION</b>	<b>1</b>
<b>FUNCTIONAL DESCRIPTION</b>	<b>1</b>
<b>REFERENCE MATERIALS LIST</b>	<b>3</b>
<b>HOST (PCI) SIDE</b>	<b>4</b>
<b>PCI CONFIGURATION REGISTERS</b>	<b>4</b>
<b>MEMORY AND REGISTER MAP SUMMARY</b>	<b>4</b>
<b>PMC OPERATION REGISTERS</b>	<b>6</b>
<b>INTERNAL ORGANIZATION</b>	<b>7</b>
SUMMIT REGISTERS	7
REMOTE TERMINAL REGISTERS	7
BUS CONTROLLER REGISTERS	8
MONITOR TERMINAL REGISTERS	9
<b>SHARED MEMORY SRAM</b>	<b>10</b>
<b>PMC SUMMIT RESOURCE REQUIREMENTS</b>	<b>10</b>
STATUS REGISTER	11
LOCAL INTERRUPT SOURCES	12
BYTE-SWAP ENABLE	12
<b>JUMPER LOCATION DIAGRAM</b>	<b>13</b>

## **GENERAL DESCRIPTION**

### **INTRODUCTION**

The PMC-1553 module provides Bus Controller (BC), Remote Terminal (RT) and Bus Monitor (BM) dual-redundant operations on the MIL-STD-1553 bus. The PMC form factor provide easy installation.

- UTMC Summit RISC based processor unit
- 64K x 16 bit dual ported SRAM
- Supports Bus Controller, Remote Terminal and Bus Monitor mode
- RT address and operational modes are program or jumper selectable
- 1553 bus long or short stub jumper option

### **FUNCTIONAL DESCRIPTION**

A functional block diagram of the PMC module is depicted below in Figure 1. The PMC-1553 is designed around the SUMMIT that is used to manage the 1553 BUS.

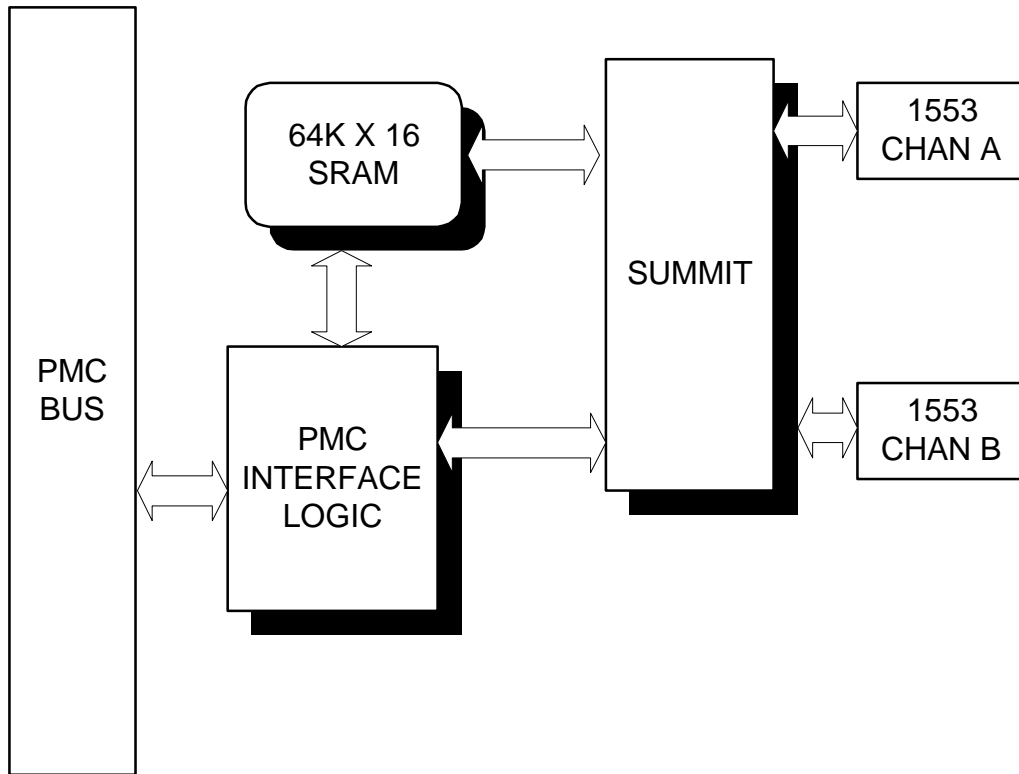

Figure 1

## **REFERENCE MATERIALS LIST**

The reader should refer to the "SUMMIT" 1996 product handbook, from UTMC, that provides detailed descriptions about the SUMMIT registers.

### **UTMC**

**1575 Garden of the Gods Road  
Colorado Springs, Colorado  
80907-3486 USA**

**Marketing Department :  
719-594-8166 or 800-722-1575**

**Technical Information :  
719-594-8252**

**Literature Requests :  
800-645-UTMC**

**WWW Home Page :  
<http://www.utmc.com>**

The reader should refer to the PCI Local Bus Specification for a detailed explanation of the PCI bus architecture and timing requirements. This specification is available from the following source:

**PCI Special Interest Group  
PO Box 14070  
Portland, OR 97214  
Tel: (800) 433-5177  
Tel: (503) 797-4207  
Fax: (503) 234-6762**

The reader is also referred to the S5933 PCI Controller data book:

**AMCC Applied Micro Circuits Corporation  
6195 Lusk Boulevard  
San Diego, CA 92121-2793  
Tel: (800) 755-2622**

## HOST (PCI) SIDE

### PCI CONFIGURATION REGISTERS

The card presents the following configuration values to the PCI system, based on the values stored in the NVRAM device read by the AMCC PCI interface chip.

Register	Value (Meaning)
Vendor ID	0x13c5 (ALPHI Technology)
Device ID	0x0306 (PMC-1553)
Revision ID	0x00
Class Code	0xff0000 (Device does not fit into defined class codes)
Interrupt Line	0xff
Interrupt Pin	A
Multifunction Device	No
Build In Self Test	No
Latency Timer	0x00
Minimum Grant	0x00
Maximum Latency	0x00
Expansion ROM Size	None

**Table 0.1: PMC Configuration Registers**

### MEMORY AND REGISTER MAP SUMMARY

The addresses for the following registers and memory locations are based upon the assignment from the host processor. The PMC-1553 uses 3 of the 5 AMCC mapped base address registers. These base address registers are written by the PCI configurator after scanning the AMCC configuration space. The AMCC is normally programmed at the factory to request the following resources:

- 64 bytes of memory space for the AMCC PMC Operation Registers.
- 128 bytes for the SUMMIT registers and local STATUS Registers.
- 128 Kbytes of space for the Dual Ported SRAM

Base address registers 2 and 4 are not used and are disabled at the factory. The following table specifies address offsets relative to the AMCC base address registers. For example, the AMCC PMC registers occupy 64 bytes of contiguous space relative to Base address 0. If the PMC configuration programs Base address 0 with the value \$6000, then the AMCC registers would occupy memory locations 6000 to 603F.

BASE ADDR	FROM	TO	DESCRIPTION	TYPE
0	00000000h	0000003Fh	AMCC PMC Operation Registers	MEM
1	00000000h	0000007Fh	SUMMIT IO Space	MEM
3	00000000h	0001FFFFh	SUMMIT DUAL PORTED SRAM	MEM

**Table 2**

**NOTE:** *The AMCC has been programmed to request memory above 1 Mbyte.*



**PMC OPERATION REGISTERS**

The host processor communicates with the PMC-1553 module via the AMCC pass-through interface. After the base address registers have been programmed by the PMC configurator, PMC bus cycles are “passed through” to the local bus. Therefore, the PMC Operation Registers are not normally used by applications software. Only IMB4 Byte 3, MBEF, and INTCSR are useful to the PMC-1553 module. IMB4 is written by the PMC-1553 hardware when the SUMMIT generates an interrupt. The PMC Operation Register Offsets are shown below:

<b>Offset</b>	<b>Register Name</b>
00h	OMB1 Outgoing Mailbox Register 1
04h	OMB2 Outgoing Mailbox Register 2
08h	OMB3 Outgoing Mailbox Register 3
0Ch	OMB4 Outgoing Mailbox Register 4
10h	IMB1 Incoming Mailbox Register 1
14h	IMB2 Incoming Mailbox Register 2
18h	IMB3 Incoming Mailbox Register 3
1Ch	IMB4 Incoming Mailbox Register 4
20h	FIFO Register Port (bi-directional)
24h	MWAR Master Write Address Register
28h	MWTC Master Write Transfer Counter
2Ch	MRAR Master Read Address Register
30h	MRTC Master Read Transfer Counter
34h	MBEF Mailbox Empty/Full Status
38h	INTCSR Interrupt Control/Status Register
3Ch	MCSR Bus Master Control/Status Register

**Table 3**

For more information about these registers refer to the AMCC PMC controller manual.

**INTERNAL ORGANIZATION**

The PMC-1553 facilitates host access to the :

- SUMMIT Registers
- Dual Port SRAM
- Status register

**SUMMIT REGISTERS**

**REMOTE TERMINAL REGISTERS**

Register Number	Name	Register Offset
0	Control Register	\$00
1	Operational Status Register	\$02
2	Current Command Register	\$04
3	Interrupt Mask Register	\$06
4	Pending Interrupt Register	\$08
5	Interrupt Log List Pointer Register	\$0A
6	BIT Word Register	\$0C
7	Time-Tag Register	\$0E
8	Remote Terminal Descriptor Pointer Register	\$10
9	Status Word Bits Register	\$12
10-15	Not Applicable	\$14-\$1E
16-31	Illegalization Registers	\$20- \$3E

**Table 4**

**BUS CONTROLLER REGISTERS**

Register Number	Name	Register Offset
0	Control Register	\$00
1	Operational Status Register	\$02
2	Current Command Block Register	\$04
3	Interrupt Mask Register	\$06
4	Pending Interrupt Register	\$08
5	Interrupt Log List Pointer Register	\$0A
6	BIT Word Register	\$0C
7	Minor-Frame Timer	\$0E
8	Command Block Pointer Register	\$10
9	Not Applicable	\$12
10	BC Command Block Initialization Count Register	\$14
11-31	Not Applicable	\$16- \$3E

**Table 5**

**MONITOR TERMINAL REGISTERS**

Register Number	Name	Register Offset
0	Control Register	\$00
1	Operational Status Register	\$02
2	Current Command Block Register	\$04
3	Interrupt Mask Register	\$06
4	Pending Interrupt Register	\$08
5	Interrupt Log List Pointer Register	\$0A
6	BIT Word Register	\$0C
7	Time-Tag Register	\$0E
8-10	Not Applicable	\$10-\$14
11	Initial Monitor Command Block Pointer Register	\$16
12	Initial Monitor Data Pointer Register	\$18
13	Monitor Block Counter Register	\$1A
14	Monitor Filter Register	\$1C
15	Monitor Filter Register	\$1E
16-31	Not Applicable	\$20- \$3E

**Table 6**

**SHARED MEMORY SRAM**

The PMC-1553 has a 64K x 16-bit Shared Memory. The base address of the SRAM is provided by the PMC host controller. A local Flash E<sup>2</sup>prom defines the resources needed by the PMC-1553 module. SRAM access are only in 16-bit mode. Arbitration between the Summit and the PMC Bus is made by the local hardware. Summit access to the SRAM takes priority over any pending host access. Therefore, the host access will be held off until the Summit access completes.

**PMC SUMMIT RESOURCE REQUIREMENTS**

**SHARED MEMORY SPACE**

NAME	OFFSET	DATA	R/W	COMMENTS
MEM SPACE	\$0 - \$1FFFF	D00-D15	R/W	Shared / Static RAM 64K x 16-bit (128Kbytes)

**SUMMIT REGISTER SPACE**

NAME	OFFSET	DATA	R/W	COMMENTS
SUMMIT REGISTERS	\$00-\$3F	D00-D15	R/W	SUMMIT Registers
PMC STATUS	\$42-\$43	D00-D15	R	Status Register Only D00-D07 is valid

**STATUS REGISTER**

The STATUS register is used to determine the status of PMC-1553 jumper settings. The Status Register provides the following status bits:

Bit	Name	Function
0	MSEL0	Summit mode of Operation
1	MSEL1	
2	LOCK	Status of the Lock input Pin
3	READY	Status of the Ready Output Pin
4-7	NOT USED	

**Table 7 Status register**

**SUMMIT MODE OF OPERATION**

Mode select 0, in conjunction with Mode select 1, determines the Summit mode of operation. The table below describes these modes.

MSEL1	MSEL0	Mode Of Operation
0	0	Bus controller = SBC
0	1	Remote Terminal = SRT
1	0	Monitor Terminal = SMT
1	1	SMT/SRT

**Table 8**

**LOCK**

This read only bit reflects the inverted state of the LOCK input pin. The LOCK pin is latched on the rising edge of MRST. If the mode of operation must change, the user must perform a MRST.

**READY**

This read only bit reflects the inverted state of the output pin READY and is cleared on reset. This signal indicates the Summit has completed initialization or BIT, and regular execution may begin.

**LOCAL INTERRUPT SOURCES**

The SUMMIT has two (2) interrupt lines. These interrupts are Ored to the INTREQ0 pin on the PMC bus. The Summit will provided the Interrupt Vector Register contents to the PMC bus on D00-D07 during an interrupt acknowledge cycle.

The source of each interrupt is listed below:

<b>INTERRUPT name</b>	<b>Description</b>
MSG_INT	Message interrupt. This pin is active for three clock cycles upon the occurrence of interrupt events which are enabled.
YF_INT	You failed Interrupt. This pin is active for three clock cycles upon the occurrence of interrupt events which are enabled.

**Table 9**

**BYTE-SWAP ENABLE**

The PMC-1553 has the ability to perform hardware byte-swapping. The jumper TTJ1 determines the behavior of the byte-swapping hardware. When TTJ1 is OPEN, no swapping occurs (Little-Endian). When TTJ1 is SHORTED, swapping occurs (Big-Endian). This feature allows the PMC-1553 memory and registers to appear correctly to Big-Endian Processors such as the PowerPC.

JUMPER LOCATION DIAGRAM

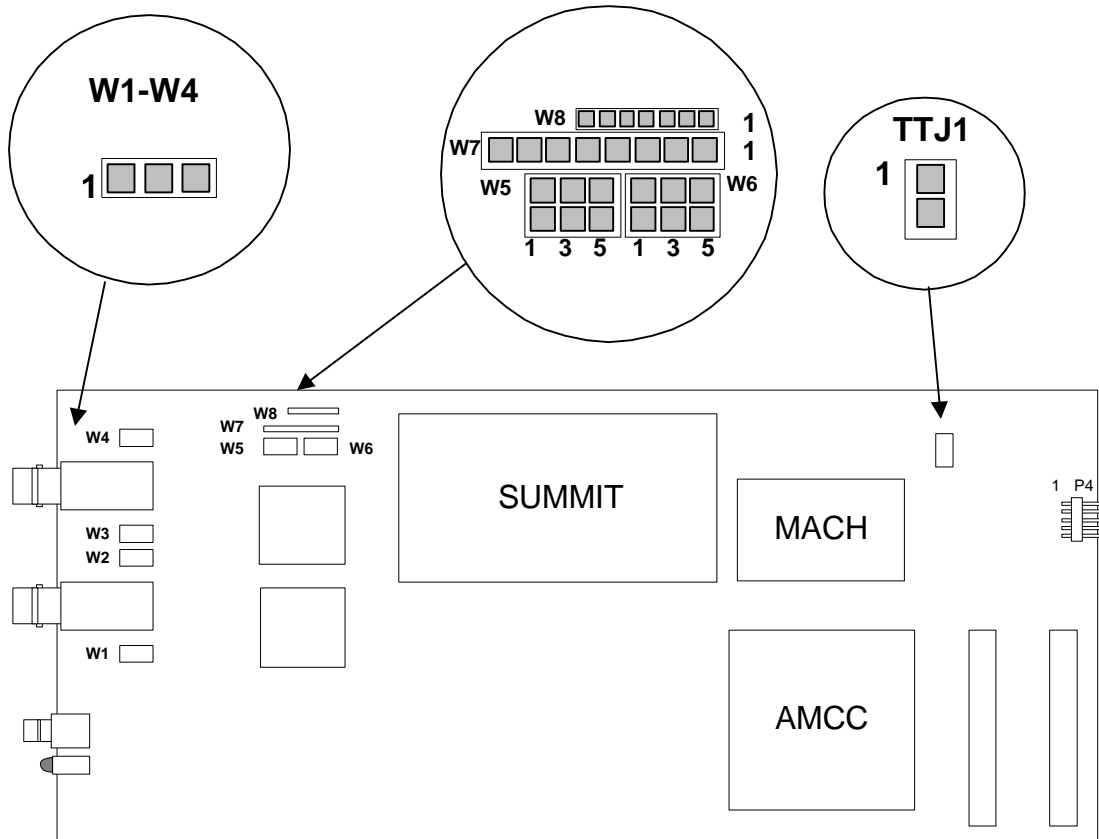

Figure 2



JUMPER	FACTORY SETTING	DESCRIPTION
W1	1-2	Long Stub/Short Stub Output channel A - ( Short Stub )
W2	2-3	Long Stub/Short Stub Output channel A + ( Short Stub )
W3	2-3	Long Stub/Short Stub Output channel B + ( Short Stub )
W4	1-2	Long Stub/Short Stub Output channel B - ( Short Stub )
W5	None	Remote terminal address RTA3-RTPT
W6	None	Remote terminal address RTA0-RTA2
W7	None	Mode of Operation of the SUMMIT
W8	None	Summit JTAG test
TTJ1	None	Byte-Swap Enable
P4	None	MACH 445 programming plug

Table 10

**W7 Mode of Operation Jumper Selection**

Signal	Jumper set	Description
A/B* STD	1-2	Military standard Mil_STD_1553A or Mil_STD_1553B
LOCK	3-4	This Pin when set active prevent Software change to both the RT address,A/B* STD and Mode select
MSEL1	5-6	See Mode of Operation Table above
MSEL0	7-8	See Mode of Operation Table above

Table 11

**W6 RT Address Selection**

Signal	Jumper set	Description
RTA2	1-2	RT Address BIT 2
RTA1	3-4	RT Address BIT 1
RTA0	5-6	RT Address BIT 0

Table 12

**W5 RT Address Selection**

Signal	Jumper set	Description
RTPT	1-2	RT Address Parity
RTA4	3-4	RT Address BIT 4
RTA3	5-6	RT Address BIT 3

Table 13

**TTJ1 Byte-Swap Enable**

Jumper set	Description
1-2	Open=Little-Endian(PCI Default), Shorted=Big-Endian

**Table 14**

**CONNECTION HARDWARE FOR 1553 BUS**

The following hardware is available from:

Trompeter Electronics, Inc.  
31186 La Baya Drive  
P.O. Box 5069  
Westlake Village, CA  
91362-4047

Phone: (818) 707-2020  
Fax : (818) 706-1040

PL155-29	Mating plug for P2 and P3 (1553 Channels A and B)
TWC-78-1	Cable meets 1553B requirements, 78 Ohm impedance

TNGM1-1-78	78 Ohm terminator
BN153	Tee connector

Contact the above manufacturer for other cabling options. They also can build complete cable assemblies to meet your requirements.