

**Intelligent CPCI Quad Industry Pack Carrier
 With TM 320C6317B DSP**

Features

- Based around the Texas Instruments floating-point Digital Signal Processor TMS320C6713B at 300 MHz
- Quad industry pack carrier configuration enabling a vast array of I/O possibilities creating a cost effective solution of DSP and I/O
- Up to 192 I/O
- 6U Compact PCI bus compatible
- Front panel I/O
- Virtually an unlimited customization of the input-output functions as well as hardware-accelerated, signal processing
- Adds high-speed, low latency IO and deterministic control to a low cost PC system solution

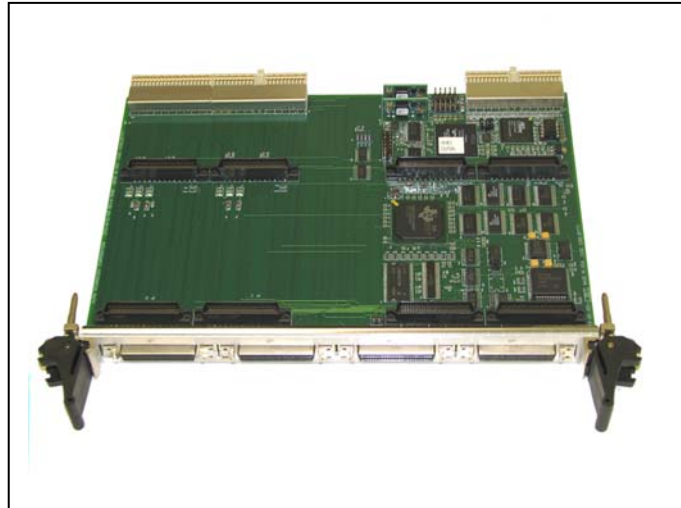

Block Diagram Overview

The board consists of private SDRAM and Flash memory attached to the 300 MHz TMS320C6713B DSP. An FPGA provides the timing and control. Peripherals include a serial port and connectors for IP mezzanine boards. Flash memory is available for downloading programs into a non-volatile memory. A PCIbus connector provides the interface to the host computer. A serial port is available for debugging.

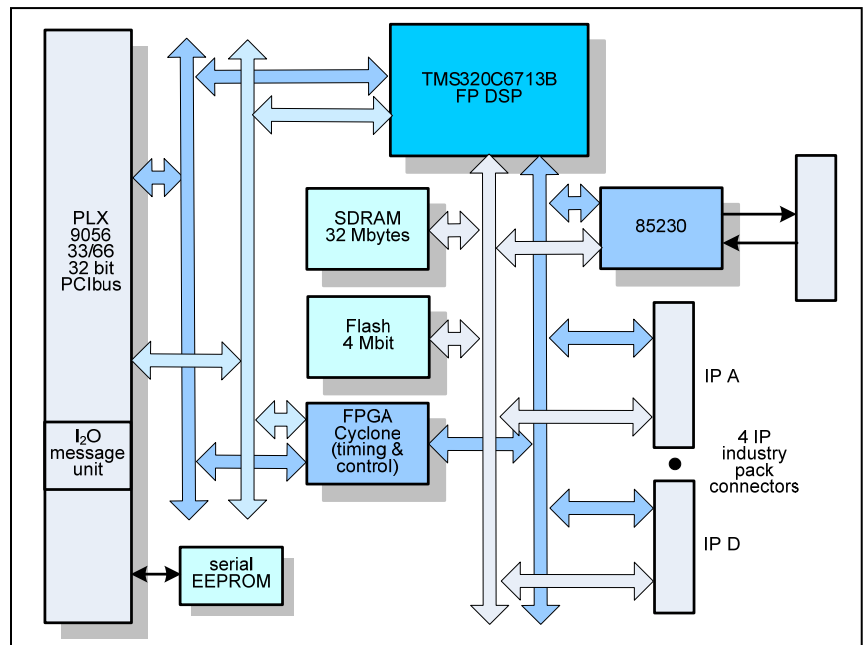

Available Software Drivers and Software Tools:

- C library dll's
- Linux drivers
- Window XP drivers
- VxWorks drivers

The TMS320C67x DSP generation is supported by the TI eXpressDSP™ set of industry development tools, including a highly optimizing C/C++ Compiler, the Code Composer Studio™ Integrated Development Environment (IDE), JTAG-based emulation,

real-time debugging, and the DSP/BIOS™ kernel.

Applications:

For application requiring low cost, high density I/O or unique combinations, the CPCI-6713B-2IP is the perfect solution. The Local DSP can be used to simply move data to and from the CPCI bus or provide pre processing functions such as local PID controls, FFT's, digital filtering, etc. Custom application software can be downloaded to the DSP via the CompactPCI bus.

TMS320C6713 DSP Features:

- TMS320C6713B™ DSP @ 300 MHz
- 32/64 bit data word
- 8 32-bit instructions/cycle
- Up to 2400 MIPS/MFLOPS
- Advanced very long instruction word DSP core with 8 independent functional units – 2 ALU's (fixed point, 4 ALU's (floating/fixed point, and 2 multipliers (floating/fixed point
- L1/L2 memory architecture; 4K byte L1P program cache, 4K byte L1D data cache (2-way), 256 K byte L2 memory total with 64K-Byte L2 Unified Cache/Mapped RAM, and 192K-Byte Additional L2 Mapped RAM
- Load-store architecture with 32 32-bit general purpose registers
- Native instructions for IEEE 754 single and double precision operations
- 32-bit external memory interface with a glueless interface to SRAM, EPROM, Flash, SBSRAM, and SDRAM with 512 Mbyte total addressable external memory space
- Dual 32 bit general purpose timers
- 16 channel EDMA 'Enhanced DMA'
- Two inter-integrated circuit bus (I²C Bus)
- 16-bit Host-Port Interface (HPI)
- IEEE-1149.1 (JTAG) boundary scan compatible

PCI Bus:

- PLX 9056 33/66MHz 32-bit, PCI r2.2 compliant
- Motorola PowerQUICC and generic 32-bit, 66MHz local bus modes
- 3.3V I/O, 5V tolerant bus interfaces
- PICMG 2.1 r2.0 hot swap
- Zero wait state burst operation, with PCI bus bursts to 264 MB/sec and local bus bursts to 264 MB/sec
- 2 DMA channels
- Direct master data transfers
- Direct slave data transfers

PCI Bus Control:

- I₂O r1.5 messaging unit
- 8 mailboxes and 32 doorbell registers
- PCI arbiter supports 7 external masters
- Host mode reset/interrupt
- Power management event generation support
- Serial EEPROM interface
- JTAG boundary scan



85C30 Specifications:

- 2 serial channels
- Up to 1Mbps using a 16MHz clock, synchronous mode
- 5, 6, 7, or 8 bits per character
- 1, 1 1/2, or 2 stop bits
- Odd or even parity
- X1, x16, x32, or x64 clock modes
- Character-oriented synchronous capabilities
- SDLC/HLDC capabilities
- NRZ, NRZI, or FM encoding/decoding
- Each serial channel has independent baud rate generator
- DPLL for clock recovery

Industry Pack Specifications:

- Meets ANSI/VITA 4-1995
- 8/32 MHz synchronous operation
- Supports ID, 128 byte I/O, interrupt. & 8 Mbyte memory spaces
- 2 Interrupts per module
- Two passive DMA channels are possible.
- Hardware self timed per IP module
- Triggered via system reset and software control
- Jumper or software time-out function
- 5, +/-12 volt reset-able fuse per IP
- 8/16 bit data on 3U board, 32 bit on 6U board

Operating Environment:

- Operating temperature
 Commercial: 0 to +70 °C
 Optional: -25 °C to +80 °C
- Non-operating: -40 °C to +85 °C
- Airflow requirement – 5 CFM
- Humidity – 5 to 90% (non-cond)
- Altitude – 0 to 10,000 feet

Mechanical Environment:

- Size – 6U CPCI module
 233.35mm x 160mm
- Power – 1.5 watt
- Vibration – 0.5G, 20-2000 Hz rand
- Shock – 20G, 11 msec, 1/2 sine
- Weight – 4-5 ounces
- MTBF – >250,000 hours

Ordering Information:

CPCI-6713B-4 IP 6U industry pack carrier with 320C6713B DSP

Optional Accessories

CBL-50-HRS Cable
 TB-50-HRS Terminal block