

Single or Dual DDC ACE 1553 Controller

Features

- 1 or 2 controllers of dual redundant (A/B channel) 1553 communications
- Programmable bus controller, remote terminal, or monitor terminal modes
- MIL-STD-1553 A and B compliant, Notice 2 RT
- STANAG 3838 bus compliant for NATO standard support
- Long or short stub support
- Low power consumption
- PCIMG compliant
- Single +5 VDC supply

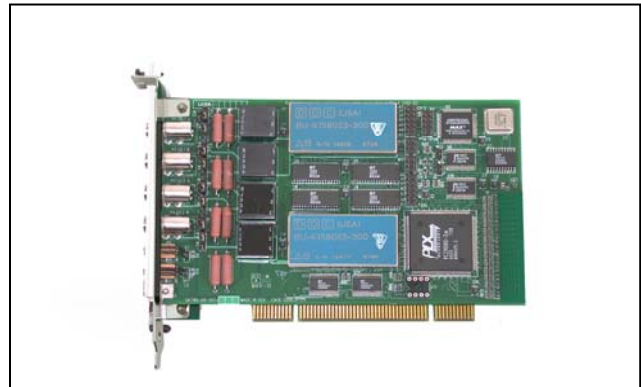

Block Diagram Overview

The PCI-1553-DDC uses Data Device Corporation's ACE, DDC enhanced mini BU-61865G4-290 communication device as its 1553 bus controller, or remote terminal, or monitor terminal. A single controller has two redundant channels. This controller has 64Kx17 word of internal memory and internal transceivers for both channel A and B. The 3U PCI board has on-board transformers. This board has a PCI compliant interface.

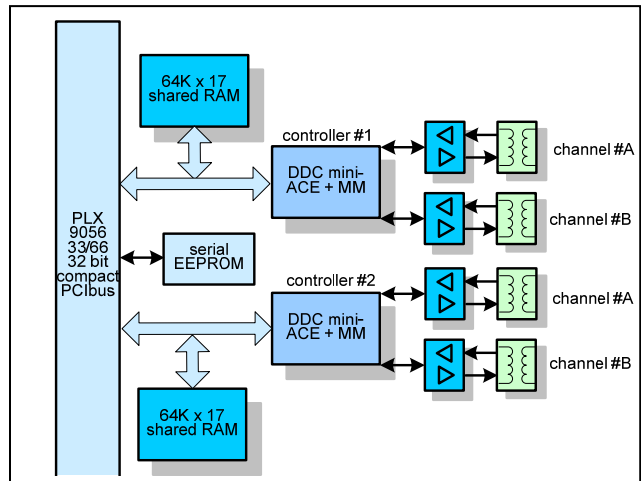

Available Software Drivers:

- C library dll's
- Linux drivers
- Window XP drivers
- VxWorks drivers

Applications:

This is a perfect solution for a wide array of 1553 communication applications such as:

- Test equipment supporting evaluation, simulation, monitoring, and analysis,
- Operational equipment such as avionics, space satellite systems, aircraft onboard systems, commercial systems, etc.
- Applications that require dual functionality of the terminal for monitoring and remote operation at the same time

1553 Compliance/Characteristics:

- Data Rate – 1 MHz
- Word Length – 20 bits
- Data Bits/Word – 16 bits
- Message Length – maximum of 32 data words
- Transmission Technique – half-duplex
- Operation – asynchronous
- Transmission encoding – Manchester II, bi-phase
- Protocol – command/response
- Bus Control – single or multiple
- Fault tolerance – typically dual redundant, second bus in "hot backup" status
- Message formats – controller to terminal, terminal to controller, terminal to terminal, broadcast, system control
- Number of remote terminals – maximum 31
- Terminal Types – remote terminal, bus controller, bus monitor
- Transmission Media – twisted shielded pair
- Coupling – transformer and direct

PCI Bus:

- PCI Bus Interface 3.3VDC/5VDC
- PLX 9056 33/66MHz 32-bit, PCI r2.2 compliant
- 3.3V I/O, 5V tolerant bus interfaces
- PICMG 2.1 r2.0 hot swap
- Zero wait state burst operation, with PCI bus bursts to 264 MB/sec and local bus bursts to 264 MB/sec
- 2 DMA channels
- Direct master data transfers
- Direct slave data transfers
- 33 MHz clock
- 16-bit address
- 16-bit data

PCI Bus Control:

- I₂O r1.5 messaging unit
- 8 mailboxes and 2 doorbell registers
- PCI arbiter supports 7 external masters
- Host mode reset/interrupt
- Power management event generation support
- Serial EEPROM interface
- JTAG boundary scan

Debug Port:

- JTAG emulator port, RS-232 RJ45

Operating Environment:

- Operating temperature
 Commercial: 0 to +55 °C
 Optional: -25 °C to +80 °C
 Non-operating: -40 °C to +85 °C
 Airflow requirement – 5 CFM
 Humidity – 5 to 90% (non-cond)
 Altitude – 0 to 10,000 feet

Mechanical: Environmental:

- Size – 3U CPCI module
 100mm x 160mm
- Power – 1.5 watt
- Front panel I/O
- Vibration – 0.5G, 20-2000 Hz rand
- Shock – 20G, 11 msec, ½ sine
- Weight – tbd
- MTBF – >250,000 hours

Terminal Electrical Input Characteristics:

Requirements	Transformer coupled	Direct Coupled
Input level ¹	0.866-14.0V	1.2-20.0V
No response ¹	0.0-0.2V	0.0-0.28V
Zero crossing stability	+/-150.0 nSec	+/_ 150.0 nSec
Rise/fall times	0 nsec – Sine	0 nsec – Sine
Noise rejection ²	140 mV WGN	200 mV WGN
Common mode rejection ³	+/- 10.0V peak	+/- 10.0V peak
Input impedance ⁴		

Notes on measurement conditions:

1. p-p, I-I
2. BER 1 per 10⁷
3. Line-ground DC-2 MHz
4. 75 KHz-1MHz

Terminal Electrical Output Characteristics:

Requirements	Transformer coupled	Direct Coupled
Output level ¹	18.0-27.0V	6.0-9.0V
Zero crossing stability	25.0 nsec	25.0 nsec
Rise/fall ²	100-300 nsec	100-300 nsec
Max distortion ³	+/-900.0 mV	+/- 300.0 mV
Max output noise ⁴	14.0 mV	5.0 mV
Max residual voltage ³	+/-250.0 mV	+/-90.0 mV

Notes on measurement conditions:

1. p-p, I-I
2. 10%-90%
3. peak, I-I
4. rms, I-I



Ordering Information:

PCI-1553-DDC-1	MIL-1553, BC/RT/M, DDC ACE; Single, dual redundant
PCI-1553-DDC-2	MIL-1553, BC/RT/M, DDC ACE; Dual dual redundant
EngKit-1553	2 T's, 2 Terminators, 2-1 meter cables

Optional Accessories

CBL-1553-1	Standard-standard 2 meter 1553 cable
CBL-1553-2	Standard-mini 2 meter 1553 cable
CBL-1553-3	Mini-mini 2 meter 1553 cable