

Summary

The Linear LTC®1588/ LTC1589/LTC1592 are serial input 12-/14-/16-bit multiplying current output DACs that operates from a single 5Volt supply. These SoftSpan DACs can be software-programmed for either uni-polar or bi-polar mode through a 3-wire SPI interface. In either mode, the voltage output range can also be software-programmed. Two output ranges in uni-polar mode and four output ranges in bi-polar mode are available.

The DACs are accurate to 1LSB over the industrial temperature range in both uni-polar and bi-polar modes. True 16-bit 4-quadrant multiplication is achieved with on-chip four quadrant multiplication resistors.

These devices include an internal deglitcher circuit that reduces the glitch impulse to less than 2nV-s (typ).



Software Programmable 2 μ Second DACs 16 channel 16 bit DAC with programmable outputs

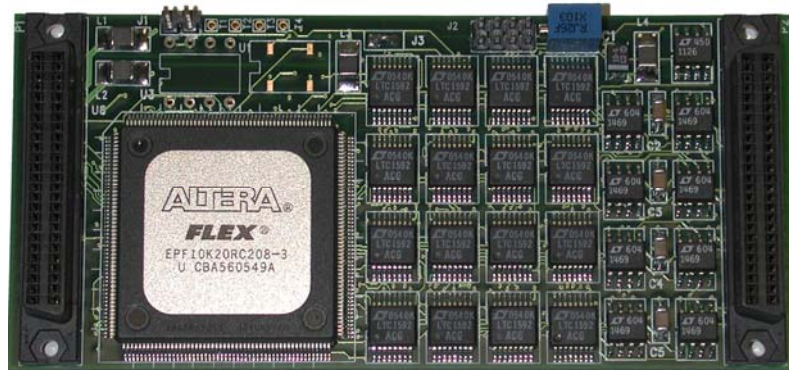

IP-SoftDAC

Features

- 2 μ S settling time, 0-5v range
- Six Programmable Output Ranges per channel
- Unipolar: 0V to 5V, 0V to 10V
- Bipolar Mode: $\pm 5V$, $\pm 10V$, $\pm 2.5V$, $-2.5V$ to 7.5V
- 1LSB Max DNL and INL Over the Industrial Temperature Range
- Glitch Impulse < 2nV-s
- Power-On Reset to 0V
- Flash ram for configuration file
- Two stage buffers
- Global output buffer w/ internal or external triggering

Applications

- Process Control and Industrial Automation
- Precision Instrumentation
- Direct Digital Waveform Generation
- Software-Controlled Gain Adjustment
- Automatic Test Equipment

Programmable via

- IP Bus

IP interface

- 8/32 Mhz clock
- 16 bit data

Operating: Environmental

- Operating temperature
 Commercial: 0 to +55 °C
 Optional: -25°C to +80°C
- Non-operating: -40°C to 85 °C
- Airflow requirement: .5 CFM
- Humidity: 5 to 90% (non-cond.)
- Altitude: 0 to 10'000 ft

Mechanical: Environmental

- Size: Vita 4 Type 1 IP
 1.8" x 3.9"
- Power: +5, +12, -12 volts
- Vibration: 0.5G RMS
 20-2000 Hz rand
- Shock: 20 G, 11 ms, 1/2 sine
- Weight: tbd
- MTBF: >250000 hours

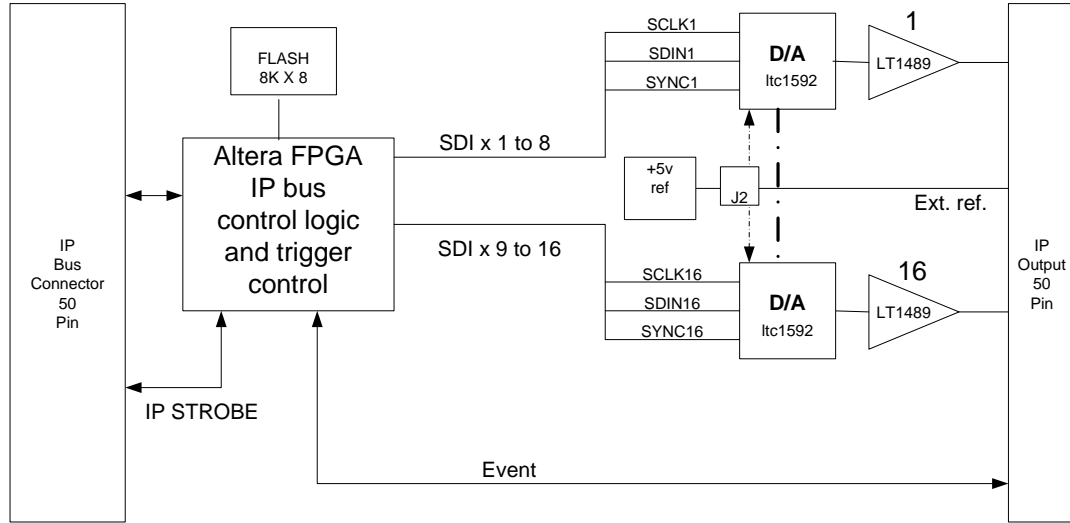

Functional Block Diagram

ORDERING INFORMATION

Part Number: IP-SoftDAC 16 Channel DAC Industry Pack Module
 IP-SoftDAC-I Same as above with -40 to +85 C

Optional Accessories

Part Number : TB-50-HDR 50 pin terminal block and 1meter flat ribbon cable
 CBL-50-HDR 50 pin,1meter flat ribbon cable, IDC header connector

Alphi Technology Corporation
 6202 South Maple Ave, Suite 120
 Tempe, Arizona 85283, USA
 Tel: (480) 838 2428
 Fax: (480) 838 4477

For ordering information: sales@alphitech.com Please visit our web site at www.alphitech.com