

# **PMC-1553-DDC**

## **MIL-STD-1553**

### **PMC Module**

#### **REFERENCE MANUAL**

Revision 1.1  
August 2001

**ALPHI TECHNOLOGY CORPORATION**  
6202 S. Maple Avenue #120  
Tempe, AZ 85283 USA  
Tel : (480) 838-2428  
Fax: (480) 838-4477

## **NOTICE**

The information in this document has been carefully checked and is believed to be entirely reliable. While all reasonable efforts to ensure accuracy have been taken in the preparation of this manual, ALPHI TECHNOLOGY assumes no responsibility resulting from omissions or errors in this manual, or from the use of information contained herein.

ALPHI TECHNOLOGY reserves the right to make any changes, without notice, to this or any of ALPHI TECHNOLOGY's products to improve reliability, performance, function or design.

ALPHI TECHNOLOGY does not assume any liability arising out of the application or use of any product or circuit described herein; nor does ALPHI TECHNOLOGY convey any license under its patent rights or the rights of others.

**ALPHI TECHNOLOGY CORPORATION**  
**All Rights Reserved**

This document shall not be duplicated, nor its contents used for any purpose, unless express permission has been granted in advance.

TABLE OF CONTENTS

<b>GENERAL DESCRIPTION</b>	<b>1</b>
<b>INTRODUCTION</b>	<b>1</b>
<b>FUNCTIONAL DESCRIPTION</b>	<b>1</b>
<b>REFERENCE MATERIALS LIST</b>	<b>4</b>
<b>FAX: (631) 567-7358</b>	<b>4</b>
<b>HOST (PCI) SIDE</b>	<b>5</b>
<b>1.0 INTERFACE TO HOST (PMC)</b>	<b>5</b>
<b>PMC CONFIGURATION SPACE</b>	<b>5</b>
<b>PMC BASE ADDRESS REGIONS</b>	<b>7</b>
<b>TABLE 3 PMC-1553-DDC-2</b>	<b>7</b>
<b>JUMPER LOCATION DIAGRAM</b>	<b>8</b>

## **GENERAL DESCRIPTION**

### **INTRODUCTION**

The PMC-1553-DDC module provides Bus Controller (BC), Remote Terminal (RT) and Bus Monitor (BM) dual-redundant operations on the MIL-STD-1553 bus. The PMC form factor provide easy installation.

The **PMC-1553-DDC-1** is installed with the following resources:

- DDC ACE RISC based processor unit
- 64K x 16 bit dual ported SRAM
- Supports Bus Controller, Remote Terminal and Bus Monitor mode
- RT address and operational modes are program or jumper selectable
- 1553 bus long or short stub jumper option

The **PMC-1553-DDC-2** is installed with the following resources:

- 2 DDC ACE RISC based processor units
- 2 64K x 16 bit dual ported SRAMs
- Supports Bus Controller, Remote Terminal and Bus Monitor mode
- RT address and operational modes are program or jumper selectable
- 1553 bus long or short stub jumper option

### **FUNCTIONAL DESCRIPTION**

A functional block diagram of the PMC module is depicted below in Figure 1. The PMC-1553-DDC is designed around the ACE that is used to manage the 1553 BUS.

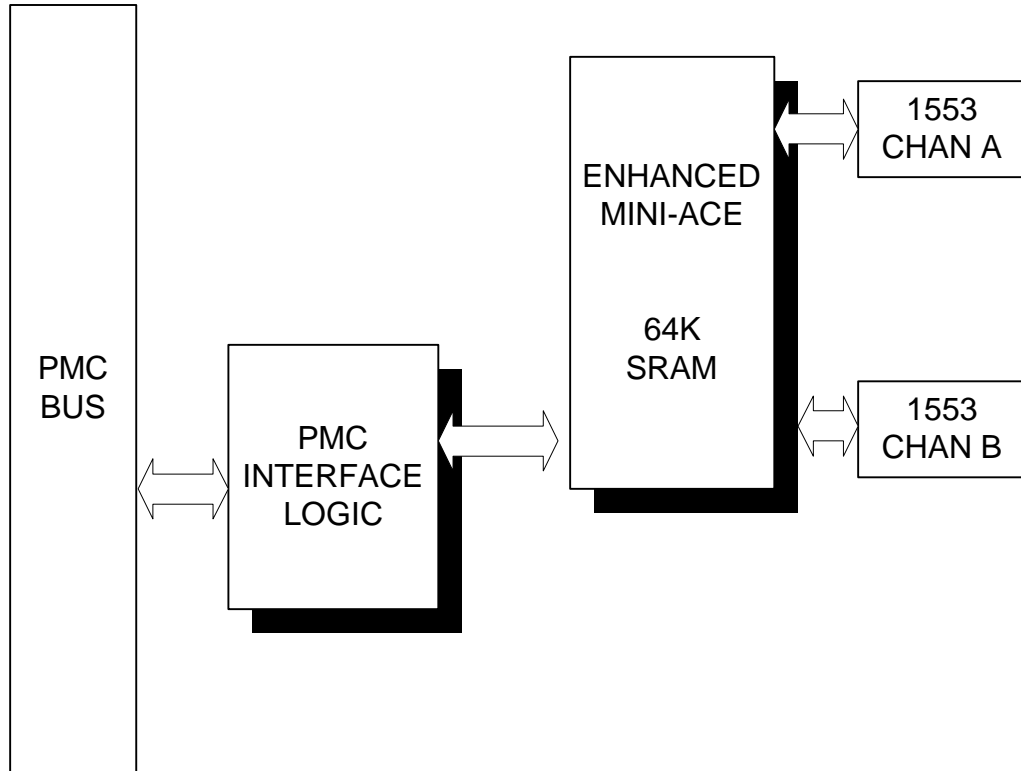

Figure 1 PMC-1553-DDC-1

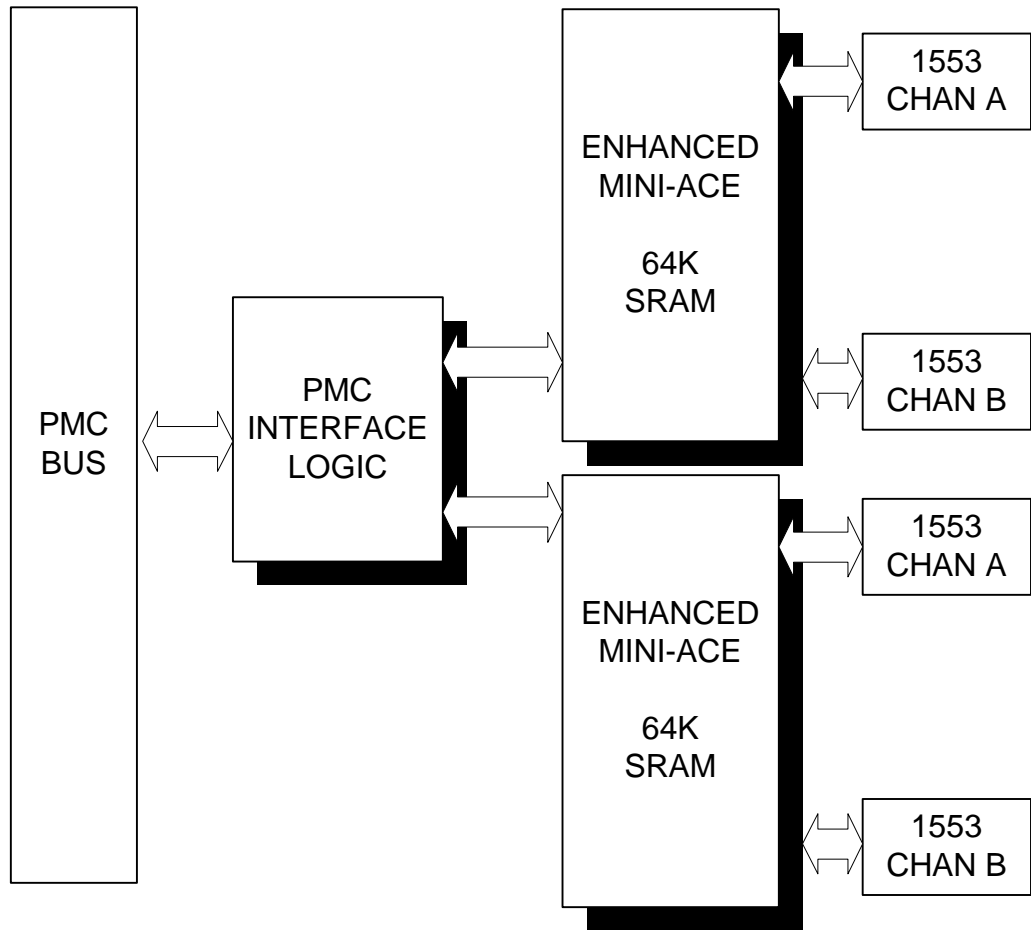

Figure 2 PMC-1553-DDC-2

**REFERENCE MATERIALS LIST**

The reader should refer to the "ACE USER'S GUIDE", from DDC, that provides detailed descriptions about the ACE registers.

**DDC**

**105 Wilbur Place  
Bohemia, New York 11716-2482**

**Marketing Department :**

**Tel: (631) 567-5600 ext. 7257 or 7381,  
Fax: (631) 567-7358**

**Technical Information :**

**1-800-DDC-5757 ext. 7257 or 7381**

**Literature Requests :**

**Headquarters - Tel: (631) 567-5600 ext. 7257 or 7381, Fax: (631) 567-7358**

**Southeast - Tel: (703) 450-7900, Fax: (703) 450-6610**

**West Coast - Tel: (714) 895-9777, Fax: (714) 895-4988**

**Europe - Tel: +44-(0)1635-811140, Fax: +44-(0)1635-32264**

**Asia/Pacific - Tel: +81-(0)3-3814-7688, Fax: +81-(0)3-3814-7689**

**WWW Home Page :**

**<http://www.ddc-web.com>**

The reader should refer to the PCI Local Bus Specification for a detailed explanation of the PCI bus architecture and timing requirements. This specification is available from the following source:

**PCI Special Interest Group**

**PO Box 14070**

**Portland, OR 97214**

**Tel: (800) 433-5177**

**Tel: (503) 797-4207**

**Fax: (503) 234-6762**

The reader is also referred to the PLX-9080 PCI Controller data book:

**PLX TECHNOLOGY**

**6195 Lusk Boulevard**

**San Diego, CA 92121-2793**

**Tel: (800) 755-2622**

## HOST (PCI) SIDE

### 1.0 Interface to HOST (PMC)

All PCI devices contain a set of registers in Configuration Space which allow for determining the manufacturer and model of the device, determining the resources necessary for the correct operation of the device, and other configuration information. Configuration space is decoded on a per slot / device basis via a mechanism described in the PCI specification.

All PCI devices can be relocated in physical memory by means of several Base Address Registers. These registers contain the high address bits, which must be matched for any access to the card to be successful. Part of the protocol of programming the Base Address Registers allows for the transfer of information regarding the size of the regions. The actual Base Address Registers are located in Configuration Space.

Normally, configuring the card is performed by the system controller and some form of firmware or BIOS. Unfortunately, determining Base Addresses and other configuration information in Configuration Space is operating system dependent. One of the primary functions of the device driver under Windows NT is to map these resources to the user application.

The card is actually accessed through the decoded base address registers.

### PMC Configuration Space

PCI Address:            CONFIG:0x00 – 0x3C  
 Mode of Access:        Read/Write  
 Reset By                PMC Hardware Reset

The card has the following registers available to PCI Configuration Space. They are implemented in the PLX chip. The registers are also accessible from the DSP Local bus.

Offset Into PCI CFG	31 – 24	23 – 16	15 – 8	7 – 0
0x00	Device ID		Vendor ID	
0x04	Status		Command	
0x08	Class Code			Revision ID
0x0C	BIST	Header Type	PCI Latency Timer	Cache Line Size
0x10	PCI Base Address 0 (Memory Access to PLX Registers)			
0x14	PCI Base Address 1 (I/O Access to PLX Registers)			



0x18	PCI Base Address 2 (Memory Access to DSP SRAM and card registers)			
0x1C	PCI Base Address 3 (Not Used for this card)			
0x20	Unused PCI Base Address 4			
0x24	Unused PCI Base Address 5			
0x28	Cardbus CIS Pointer (Not Supported)			
0x2C	Subsystem ID		Subsystem Vendor ID	
0x30	PCI Base Address for Expansion ROM			
0x34	Reserved			
0x38	Reserved			
0x3C	Max Latency	Min Grant	Interrupt Pin	Interrupt Line

**Table 1.0 : PMC Configuration Space**

The card presents the following initial configuration values to the PMC system, based on the values stored in the NVRAM device read by the PLX PCI9080 interface chip.

Register	Value (Meaning)
Vendor ID	0x13C5 (ALPHI Technology)
Device ID	0x0110 (PMC-1553-DDC-1) 0x111 (PMC-1553-DDC-2)
Revision ID	0x00
Class Code	0xff0000 (Device does not fit into defined class codes)
Interrupt Line	0xff
Interrupt Pin	A
Multifunction Device	No
Build In Self Test	No
Latency Timer	0x00
Minimum Grant	0x00
Maximum Latency	0x00
Base Address 0 Size	0x256 Bytes Allocated
Base Address 1 Size	0x256 Bytes Allocated
Base Address 2 Size	0x256 Bytes Allocated
Base Address 3 Size	0x256 KBytes Allocated
Expansion ROM Size	None

**Table 1.1: PMC Configuration Register Default Values**

**PMC Base Address Regions**

HOST Address	WIDTH USED	Description	TYPE
BAR0	64 BYTES 0X0h– 3Fh	PLX Operation Registers	MEM
BAR1	256 BYTES	NOT USED	I/O
BAR2	128 BYTES 0X0h– 7Fh	Ch 1 EN-MINI-ACE IO Space	MEM
BAR3	128 KBYTE 0X0h– 1FFFFh	Ch 1 EN-MINI-ACE DUAL PORTED SRAM	MEM

**Table 2 PMC-1553-DDC-1**

HOST Address	WIDTH	Description	TYPE
BAR0	64 BYTES 0X0h– 3Fh	PLX Operation Registers	MEM
BAR1	256 BYTES	NOT USED	I/O
BAR2	256 BYTES: 0X0h– 7Fh 0X80h– FFh	EN-MINI-ACE IO Space Ch 1 EN-MINI-ACE IO Space (128b) Ch 2 EN-MINI-ACE IO Space (128b)	MEM MEM
BAR3	256 KBYTES 0X0h– 1FFFFh 0X20000h– 3FFFFh	EN-MINI-ACE DUAL PORT SRAM CH 1 DUAL PORT SRAM (128KB) CH 2 DUAL PORT SRAM (128KB)	MEM MEM

**Table 3 PMC-1553-DDC-2**

JUMPER LOCATION DIAGRAM

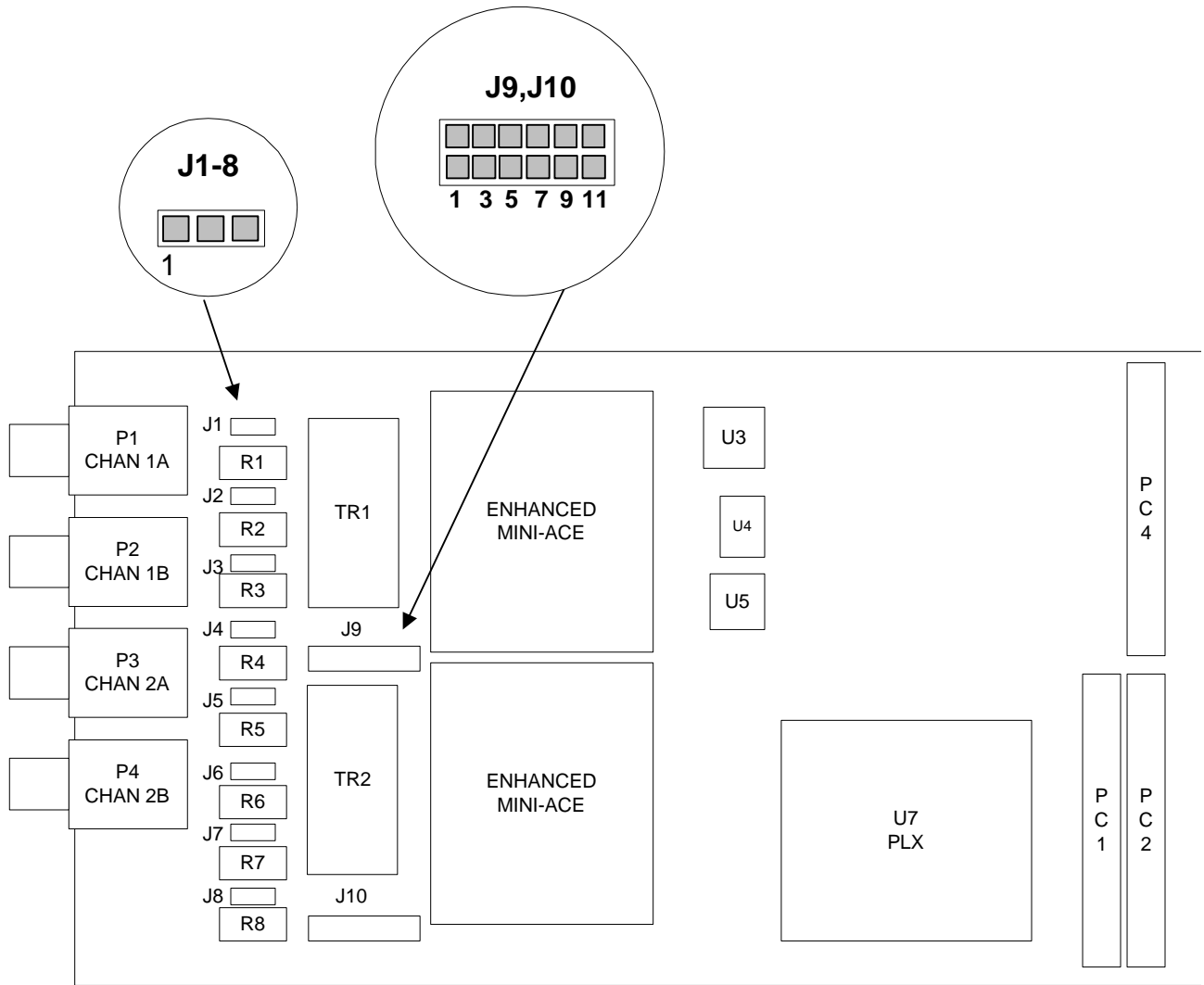

Figure 3

<b>JUMPER</b>	<b>FACTORY SETTING</b>	<b>DESCRIPTION</b>
J1	1-2	Long Stub/Short Stub Output channel 1A - ( Short Stub )
J2	2-3	Long Stub/Short Stub Output channel 1A + ( Short Stub )
J3	2-3	Long Stub/Short Stub Output channel 1B + ( Short Stub )
J4	1-2	Long Stub/Short Stub Output channel 1B - ( Short Stub )
J5	1-2	Long Stub/Short Stub Output channel 2A - ( Short Stub )
J6	2-3	Long Stub/Short Stub Output channel 2A + ( Short Stub )
J7	2-3	Long Stub/Short Stub Output channel 2B + ( Short Stub )
J8	1-2	Long Stub/Short Stub Output channel 2B - ( Short Stub )
J9	None	Remote terminal address and parity Summit 1
J10	None	Remote terminal address and parity Summit 2
P5	None	Altera programming plug

**Table 4**

**J9,10 RT Address Selection**

<b>Signal</b>	<b>Jumper set</b>	<b>Description</b>
RTPT	1-2	RT Address Parity
RTA4	3-4	RT Address Bit 4
RTA3	5-6	RT Address Bit 3
RTA2	7-8	RT Address Bit 2
RTA1	9-10	RT Address Bit 1
RTA0	11-12	RT Address Bit 0

**Table 5**

**CONNECTION HARDWARE FOR 1553 BUS**

The following hardware is available from:

Trompeter Electronics, Inc.  
 31186 La Baya Drive  
 P.O. Box 5069  
 Westlake Village, CA  
 91362-4047

Phone: (818) 707-2020  
 Fax : (818) 706-1040

PL155-29                    Mating plug for P2 and P3 (1553 Channels A and B)  
TWC-78-1                   Cable meets 1553B requirements, 78 Ohm impedance

TNGM1-1-78                78 Ohm terminator  
BN153                        Tee connector

Contact the above manufacturer for other cabling options. They also can build complete cable assemblies to meet your requirements.