

Summary

The PCI-6713B-2IP module provides a high performance flexible I/O scheme, that supports industry standard Industry Packs™. For application requiring low cost, high density I/O or unique combinations, the PCI-6713B-2IP is the ideal solution. The local 6713B DSP can be used to simply move data to and from the PCI bus or provide pre processing functions such as local PID controls, FFT's, digital filtering, etc. Custom application software can be downloaded to the DSP via the PCI bus. A very low cost, non-intelligent version is also available, PCI-SIP.

The PCI-6713B-2IP is a high performance and flexible DSP + I/O board for servo control and data acquisition. Real-time control in low cost PCI based systems. The design is based around the Texas Instruments floating-point Digital Signal Processor TMS-320C6713B. Supported by 2 Industry Pack site for I/O. There is an unlimited customization of the input-output: servo controls, military SONAR - RADAR, aerospace communication systems, test systems, adaptive control, vibration, semiconductor testing.

The 6713B DSP is supported by TI eXpress-DSP™ set of industry development tools, including a highly optimizing C/C++ Compiler, Code Composer Studio™ JTAG based emulation, real-time debugging, and the DSP/BIOS™ kernel.

Available Drivers :

- Labview / Matlab
- Linux
- Window XP



INTELLIGENT PCI DUAL INDUSTRY PACK CARRIER TMS 320C6713B DSP

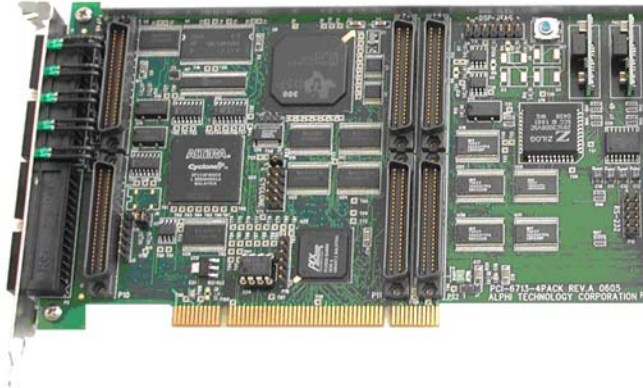

PCI-6713B-2IP

Board Features:

PCI Bus Interface 3.3 / 5 Volt via PLX 9056 33/66MHz
 High Performance Floating-Point DSP
 Up to 288MHz system clock.
 Up to 32Mbytes of SDRAM
 4.0 Mbit flash memory for bootstrap program

DSP Specifications:

TMS320C6713B™ DSP @ 288 Mhz
 64K-Byte L2 Unified Cache/Mapped RAM, and 192K-Byte Additional L2 Mapped RAM
 Dual 32 bit general purpose timers
 16 channel EDMA 'Enhanced DMA'
 16-bit Host-Port Interface (HPI)

PCI Bus:

PCI Bus Interface 3.3 / 5 Volt
 PLX 9056 33/66MHz 32-bit, PCI r2.2 compliant
 3.3V I/O, 5V tolerant bus interfaces

Debug Port:

JTAG emulator port
 RS-232 console port

IP Specifications:

(2) Dual Industry Pack Sites
 Meets ANSI Vita 4
 8/32 MHz operation
 Support ID, I/O, Int. & mem spaces
 2 Interrupts
 5, +/-12 volt reset-able fuse per IP
 Rear Panel I/O
 8/16 bit data

I/O panel connectors:

(2) 50 pin high density connector
 2 on main board

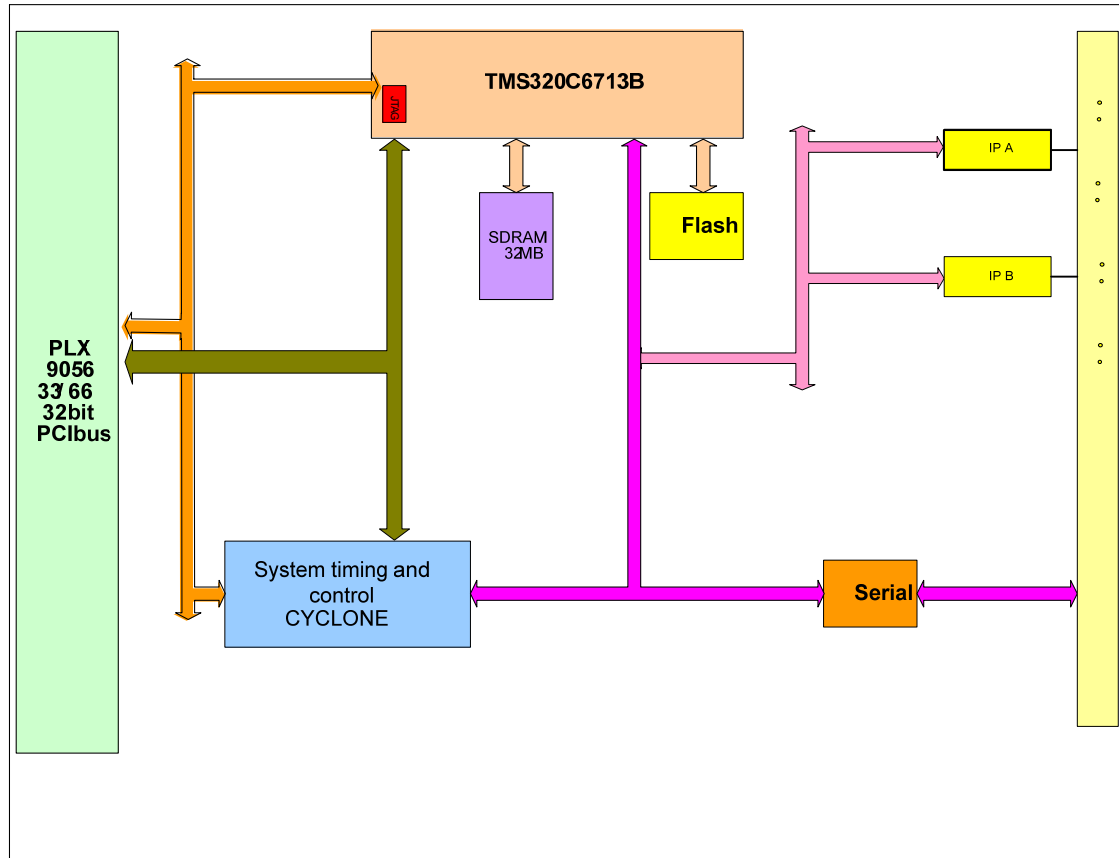

Functional Block Diagram

Mechanical & Environmental

- Operating temp. 0 to +70 °C
- Airflow requirement: 1 CFM
- Humidity: 5 to 90% (non-cond.)
- Altitude: 0 to 10'000 ft
- Full size PCI card
- Front panel I/O
- Power: +5v 1 amp, +12v 1 amp
- Vibration: 0.5G RMS 20-2KHz
- Shock: 20 G, 11 ms, ½ sine
- Weight: 2 lbs
- MTBF: >413000 hour

Ordering Information

PCI-6713B-2IP	Dual Industry Pack carrier with TMS 320C6713B
TB-50	Terminal block
CBL-50-HRS	50 pin cable, HRS

Alphi Technology Corporation
 6202 South Maple Ave, Suite 120
 Tempe, Arizona 85283, USA
 Tel: (480) 838 2428
 Fax: (480) 838 4477

For ordering information: sales@alphitech.com Please visit our web site at www.alphitech.com